

HORIZON INTERNATIONAL

C-041D, SUPERMART-1, DLF CITY PHASE 4, GURGAON-122002
HARYANA,INDIA. TEL +91-9902692031/+91-9811056235



www.horizonintl.in

HORIZON INTERNATIONAL

**C-041D, SUPERMART-1, DLF CITY PHASE 4, GURGAON-122002
HARYANA,INDIA. TEL +91-9902692031/+91-9811056235**

About us



Horizon International was founded in 2003 by leading professionals in the field of engineering and international business. They leveraged their experience with various global organizations to set up Horizon International which now serves 50+ clients in the Fortune 500 segment in India and Asia.

Horizon fulfils the needs of the manufacturing industry requiring innovative global sourcing solutions. We also provide innovative supply chain solutions for Vendor managed inventory (VMI) to various customers in Asia.

CUSTOMERS can rely on HORIZON for all their sourcing needs. Our one-stop-shop service ensures operational efficiencies and resource reduction, resulting in bottom-line savings. In cases where a company may have difficulties dealing with foreign vendors due to communication issues, payment terms, shipping or documentation requirements, HORIZON can be the solution.



PPM provides food handling systems which include vibratory and belt conveying, screening, grading and sizing conveyors for all types of fresh, frozen and processed foods.

PPM's Libra VF Mass Flow System employs a two-tier conveyor system that combines VF technology with load-cell scales, measuring product by both weight and volume. The Libra's loss-in-weight feedback system provides continuous, real-time product load measurements, adjusting product speeds to ensure feed rates are consistent and precise.

Plastic and stainless steel seasoning drums in both standard and custom sizes.

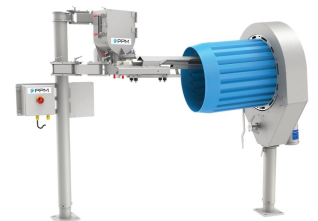
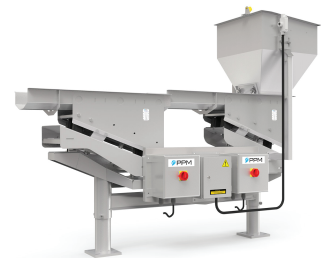

HORIZON INTERNATIONAL

C-041D, SUPERMART-1, DLF CITY PHASE 4, GURGAON-122002
HARYANA,INDIA. TEL +91-9902692031/+91-9811056235



Electro Mechanical Conveyor



PPM's VF range of conveyors continue to be the reliable and proven workhorses of the food industry

Bucket Elevators

Designed to elevate a wide range of dry, free-flowing products, including nuts, snack foods, cereals, pet foods, confectionary products

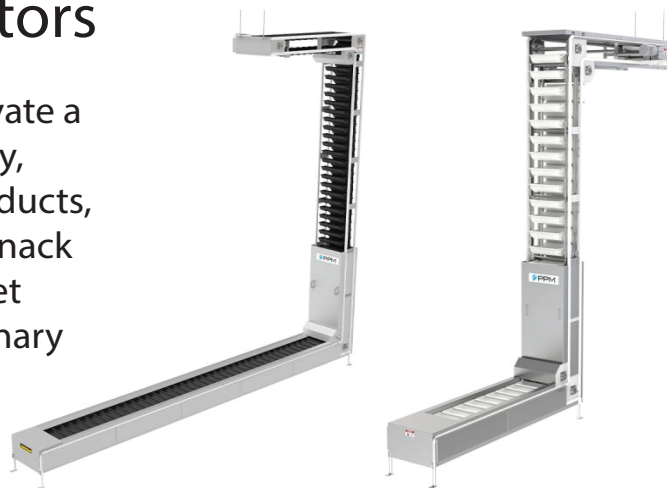

Continuous Oil Fryers

They ensure proper oil management with automatic oil-level controls, continuous oil circulation, and a variety of filtration systems that help reduce oil loss and eliminate wastage.

HORIZON INTERNATIONAL

C-041D, SUPERMART-1, DLF CITY PHASE 4, GURGAON-122002
HARYANA,INDIA. TEL +91-9902692031/+91-9811056235



Accraply is a leader in the design, manufacture and support of **automated label application systems** as well as **converting and finishing equipment** for the shrink sleeve label and flexible packaging markets.



HORIZON INTERNATIONAL

C-041D, SUPERMART-1, DLF CITY PHASE 4, GURGAON-122002
HARYANA,INDIA. TEL +91-9902692031/+91-9811056235



Accraply &

HARLAND

FLEXIBLE PACKAGING



BAGS & POUCHES
VERTICAL FORM-FILL-SEAL,
FLOW WRAPPING, FILLING,
PALLETIZING

BW Flexible Systems

- Hayssen
- Rose Forgrove
- Sandiacre
- Schib
- Simionato
- Slidell
- Symach
- Thiele

FILLING, SEALING, SEAMING & CAPPING



BOTTLES
FILLING & CAPPING

Pneumatic Scale Angelus

- Consolidated
- Hema
- Mateer
- Multi-Tech Systems
- OnTrack
- Pneumatic Scale
- Zepf Solutions

Synerlink

- Ermi



CANS
DRY & LIQUID FILLING,
SEAMING & LABELING

Pneumatic Scale Angelus

- Angelus
- Burt
- Continental/Closetech
- Hema
- Mateer
- Multi-Tech Systems
- Pneumatic Scale

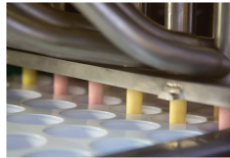

CUPS
FILLING &
FORM-FILL-SEAL

Synerlink

- Arcil
- Dairy Pack
- Dinieper
- Ermi

LABELING & SLEEVING



LABELING
CONVERTING, SHRINK
SLEEVE, ROLL-FED &
PRESSURE SENSITIVE FOR
ALL PACKAGING TYPES

Accraply

- Graham & Sleeveit
- Harland
- Stanford
- Trine

END-OF-LINE & SYSTEMS INTEGRATION



END-OF-LINE
SECONDARY PACKAGING
& SYSTEMS INTEGRATION

BW Integrated Systems

- Ambec
- Fleetwood
- Goldco
- Nigrelli
- SWF
- Streamfeeder
- Tisma

Synerlink

- Aprium

Pressure Sensitive Labeling Equipment



HORIZON INTERNATIONAL

C-041D, SUPERMART-1, DLF CITY PHASE 4, GURGAON-122002
HARYANA,INDIA. TEL +91-9902692031/+91-9811056235



HORIZON INTERNATIONAL

C-041D, SUPERMART-1, DLF CITY PHASE 4, GURGAON-122002
HARYANA, INDIA. TEL +91-9902692031/+91-9811056235

Complete processing line for creme,
jam, marshmallow



Creme filling line

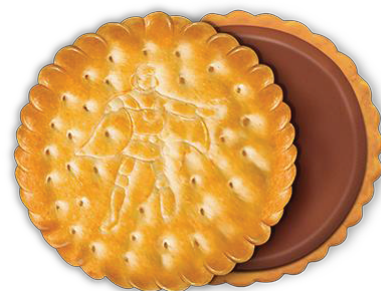

Pasteurized cream



Roto Temp SSHE



HORIZON INTERNATIONAL

C-041D, SUPERMART-1, DLF CITY PHASE 4, GURGAON-122002
HARYANA,INDIA. TEL +91-9902692031/+91-9811056235

ROSPEN

THE WEIGHING & METERING SPECIALISTS



Loss-in-Weight
(LIW) Feeders

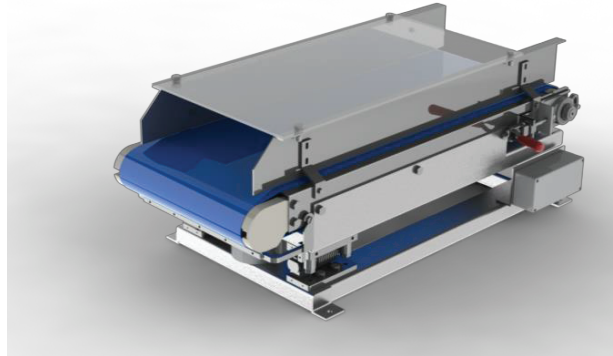

Weigh Belts

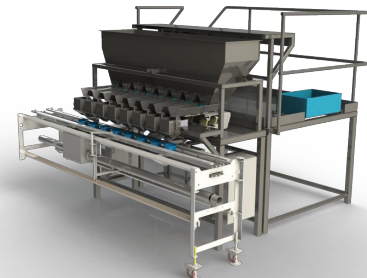

Batch Weighing



Vibratory Feeders

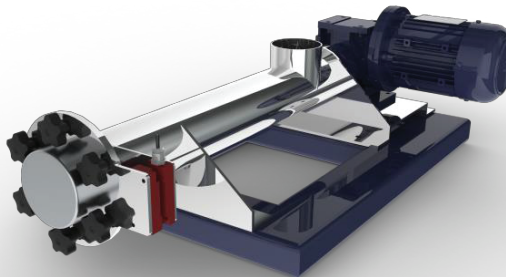

Weigh Screws



Pneumatic Conveying

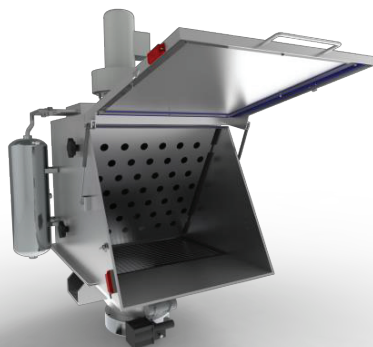

Sack/Crate Handling



Big Bag Handling

HORIZON INTERNATIONAL

C-041D, SUPERMART-1, DLF CITY PHASE 4, GURGAON-122002
HARYANA, INDIA. TEL +91-9902692031/+91-9811056235

Complete turnkey systems for food and confectionery as well as pharma, cosmetics and other industries.



Cooling Tunnel



Continuous aerator



Continuous dosing and mixing unit



Tempering and filling machine

HORIZON INTERNATIONAL

C-041D, SUPERMART-1, DLF CITY PHASE 4, GURGAON-122002
HARYANA,INDIA. TEL +91-9902692031/+91-9811056235

Pick-&-place robotics

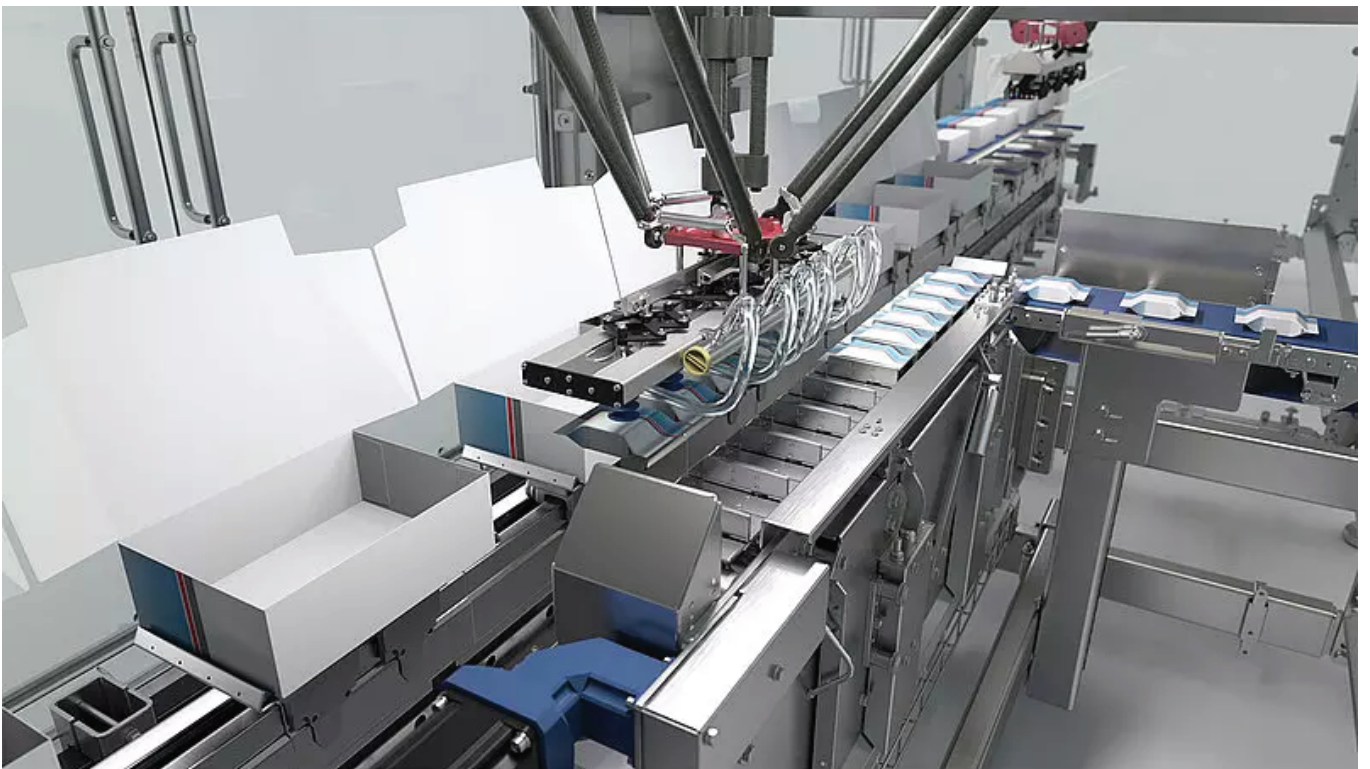

HORIZON INTERNATIONAL

C-041D, SUPERMART-1, DLF CITY PHASE 4, GURGAON-122002
HARYANA,INDIA. TEL +91-9902692031/+91-9811056235